



Air-Path Control in Diesel-Dual-Fuel Premixed-Charge-Compression-Ignition (DF-PCCI) Engine Using Supervisory Fuzzy System

Kittipong Yaovaja^{1*}, Withit Chatlatanagulchai¹, Shinapat Rhienprayoon² and Krisada Wannatong²

¹ Faculty of Engineering, Kasetsart University, 50 Phaholyothin Rd., Chatuchak, Bangkok 10900.

² PTT Research and Technology Institute, PTT Public Company Limited, 555 Vibhavadi Rangsit Rd., Chatuchak, Bangkok 10900.

*Corresponding Author: Email yaovaja@hotmail.com, Telephone (66)897670767, Fax. Number (66)25036828

Abstract

DF-PCCI engine is a type of diesel-dual-fuel engines. DF-PCCI engine, patented by PTT, uses new combustion strategy corresponding to Premixed-Charge-Combustion-Ignition (PCCI) combustion mode. Diesel injection is advanced till early of the compression stroke along with nature gas (compressed natural gas, CNG) is injected in the intake ports of each cylinder before intake valve close (IVC). Two quantities, mass fresh air flow rate (MAF) and intake manifold absolute pressure (MAP), are controlled in the air-path of the engine. Their set-points vary with wide ranges and with more abrupt changes than those of diesel engine. The engine is in need of an accurate and sophisticated air-path control system to achieve beneficial PCCI combustion efficiency. The system identification presents that throttle has primary effect on the MAP, and Exhaust Gas recirculation (EGR) valve has primary effect on the MAF. However, since throttle has secondary effect on the MAF, and the EGR valve also has secondary effect on the MAP, this so-called actuator interaction problem has to be considered in the control system design. Accordingly, the fuzzy supervisory control system is applied for the MAF and MAP tracking control.

The DF-PCCI engine, modified from a Toyota 2KD-FTV diesel engine, was connected with AVL engine test-bed and performed on New-European Driving Cycle (NEDC). The MAF and MAP tracking results showed excellent performance and enhancement by the proposed control system.

Keywords: Supervisory Fuzzy control, Air-path control, Diesel-dual-fuel engine, Engine control.

1. Introduction

Emission emitted from automotive engines has been regulated since in 1959; the state of California legislature took, as a consequence of the smog problems in Los Angeles, the first legislative steps towards a reduction of the automotive air pollution by setting emissions standards for automotive

engines. After carbon dioxide (CO₂) was identified as a greenhouse gas contributing to global warming, diesel engines have emerged as an alternative to gasoline engines due to their low CO₂ emission. While the emissions of oxides of nitrogen (NO_x) and particulate matter (PM) are main concerns.



Methane, is also abundant in the gulf of Thailand, has low hydrogen-to-carbon ratio resulting in low CO₂ emissions per energy content. Because of the short carbon chains in methane, it also generally produces low particulate emissions. The use of methane such as natural gas as alternative fuel can reduce emissions as well as increase security of supply.

The so-called diesel-dual-fuel (DDF) engine, Methane gas, compressed natural gas (CNG), is injected as the main fuel in the intake port and diesel is directly injected into cylinders as a pilot ignition. The small diesel injection ignites the methane like a "liquid" spark plug, introducing far more energy than the electrical spark plug, which increases the lean burn capability compared to the with-spark-plug case.

PTT researchers have been investigating new combustion strategies for the DDF engine to increase the performance of the engine in recent years. The DF-PCCI engine, patented by PTT, is a kind of DDF engines using the new combustion strategy corresponding to PCCI combustion. It allows the engine runs on higher fuel efficiency and lower emission release than typical DDF engines.

For the PCCI combustion strategy to work effectively, it is crucial that the air-path controller provides accurate simultaneous tracking of the MAF and MAP set-points which are varied with wide ranges and with more abrupt changes than diesel engine. Experience shows that these combustion processes are very sensitive to cyclical fluctuations in the thermodynamic state. Thus, the sophisticated MAF and MAP tracking controller can enhance drivability performance of the DF-PCCI engine.

Study on air-path control of the engine could be found in [1]-[4].

2. Engine setup

The DF-PCCI engine is a modified diesel engine by installing gas injectors. Four of port fuel injectors are installed in a Toyota 2KD-FTV engine; 2.5 liters of 4 in-line cylinders. High pressure CNG in a CNG tank is regulated to nearby 350 kPa before injected in the intake port before IVC. The gas injection slightly increases the swing of the both MAP and MAF. The engine is installed in AVL test cell with an engine dynamometer. The test cell management system is AVL PUMA, and data acquisition and control hardware is National Instruments.

The engine schematics of air-path system of Toyota DF-PCCI engine is shown in Figure 1. W_{bc} (mass fresh air flow rate before the compressor) is measured by a hot-wire MAF sensor. On a similar way, MAP sensor is placed on the intake manifold to measure fluctuation of intake manifold absolute pressure (p_i). T_{dc} is throttle control signal in duty cycle (%), and TP is feedback throttle position (%). E_{dc} is duty cycle (%) of EGR control signal, and EP is feedback EGR position (%).

3. Air-path System Identification and Analysis

System identification of the DF-PCCI engine shows the results of actuating throttle and EGR valve to affect the MAF and the MAP. Experiments were performed on constant engine speed of 2,000 RPM and 20% of pedal position.

The measured values (TP, EP, p_i, W_{bc}) are used in finding the plant transfer function matrix relating inputs (TP, EP) to outputs (p_i, W_{bc}), the plant transfer function matrix only relates the deviations of inputs to the deviations

of outputs. Therefore, in finding the plant transfer function matrix, mean values of all signals are removed. The linear dynamics system is built by using Matlab's identification toolbox. The two-by-two plant transfer function matrix (G) is found as in (1).

$$G = \begin{bmatrix} \Delta p_i \\ \Delta W_{bc} \end{bmatrix} = \begin{bmatrix} p_{11} & p_{12} \\ p_{21} & p_{22} \end{bmatrix} \begin{bmatrix} \Delta TP \\ \Delta EP \end{bmatrix}$$

$$= \begin{bmatrix} \frac{0.101}{0.01192s+1} & \frac{-0.2001}{2.165s+1} \\ \frac{0.1197}{0.001619s+1} & \frac{-0.4157}{0.001s+1} \end{bmatrix} \begin{bmatrix} \Delta TP \\ \Delta EP \end{bmatrix}$$

p_{11} and p_{21} were found by closing EGR fully and allowing TPS to follow a frequency-varying square wave. p_{12} and p_{22} were found by opening TPS fully and allowing EGR to follow a frequency-varying square wave.

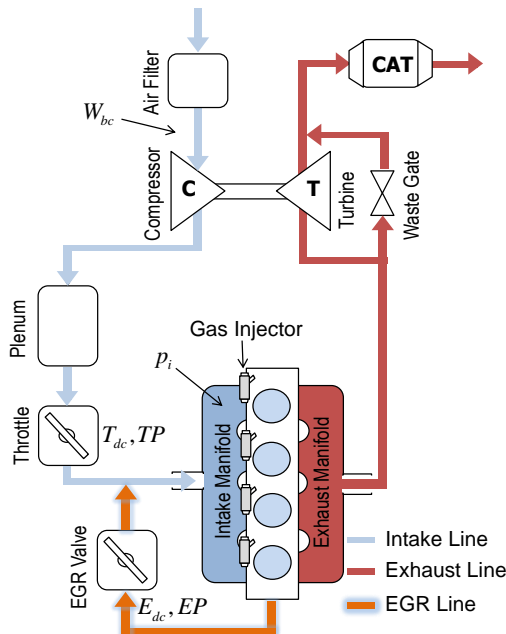

Figure 1: Schematic of air-path system in the DF-PCCI engine.

Throttle position primarily affects to the MAP, and the primary effect of EGR position dominates to the MAF. However, since throttle also has secondary effect on the MAF, and the EGR valve also has secondary effect on the MAP, this so-called actuator interaction is

investigated by the MIMO frequency analysis tool; Relative Gain Array (RGA), [5].

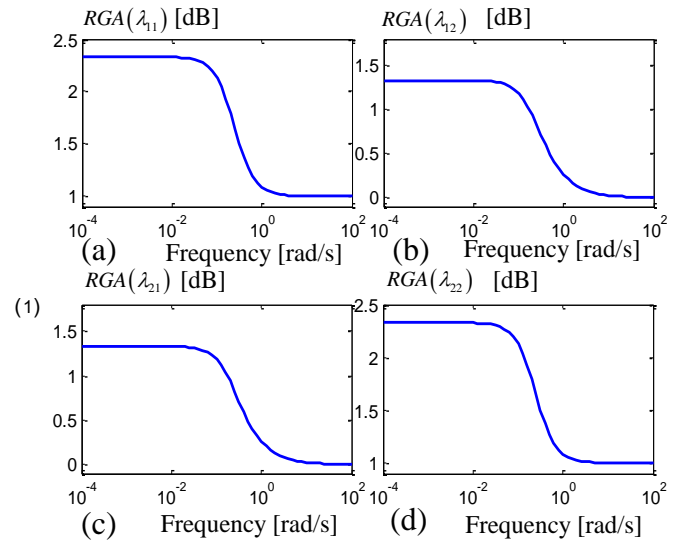

Figure 2: Relative Gain Array (RGA)

The two-by-two plant transfer function matrix is used in the analysis. The RGA elements λ_{ij} of the plant are shown in Figure 2. None of the RGA elements at steady state ($\omega=0$) are negative values which cause instability. Diagonal pairing displays lesser RGA-magnitude over the whole frequencies; including crossover frequencies. It can be concluded that diagonal pairing is an appropriated pairing of inputs and outputs when using a decentralize controller; used in the proposed control system.

4. Fuzzy controller design

Air-path fuzzy control can be found in ref. [6]-[9]. In this section, the supervisory fuzzy system control design of the MAF and MAP in the DF-PCCI engine is explicated, [10] gives fundamental of fuzzy control system. The controller schematic is given in **ชนิดพลาด! ไม่พบแหล่งอ้างอิง**. The control system consists of two separated fuzzy supervisory control systems. One is the MAP tracking control by actuating throttle position, and another is the MAF tracking control by

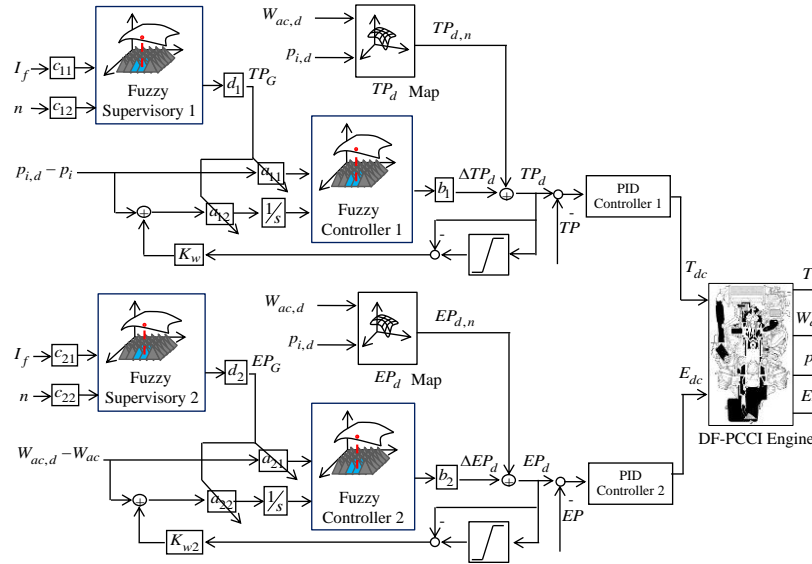

Figure 1: Fuzzy Supervisory Control System of Air-path in the DF-PCCI engine.

actuating EGR valve position. Each of fuzzy system consists of a standard fuzzy controller, a standard fuzzy supervisor, feed-forward maps, and a PID controller.

The fuzzy controller, with MAP tracking error ($p_{i,d} - p_i$) and its integral as inputs, is used to generate a desired variation of the throttle position set-point (ΔTP_d) to minimize the tracking error. The fuzzy supervisor, with the interaction parameter (I_f) and engine speed (n) as inputs, generates an appropriate input scaling gain for the fuzzy controller to obtain more appropriate throttle variation. The feed-forward map outputs a nominal throttle position ($TP_{d,n}$) for each MAF and MAP. The variation and the nominal values are added to produce appropriate throttle position set-point (TP_d). The PID controller regulates the throttle position at

their set-points. The EGR fuzzy system is similar to the throttle fuzzy system but with the MAF instead of the MAP. Details of the control system are described later.

4.1 MAF and MAP Set-points

Appropriate MAF set-points ($W_{bc,d}$) and MAP set-points ($p_{i,d}$) as functions of time were previously found experimentally by using air-fuel ratio control algorithm. The set-points could be a function of several engine control parameters depending on their control strategy.

4.2 Feed forward maps

The feed-forward map (TP_d Map) outputs a nominal throttle position ($TP_{d,n}$) for each MAF and MAP set-points. The EGR feed-forward map is similar to the throttle system. There is the feed-forward map (EP_d Map) outputs a nominal EGR position ($EP_{d,n}$). In this paper, $TP_{d,n}$ and $EP_{d,n}$ are set to a constant



value (50 %) in order to entirely demonstrate the fuzzy controller's efforts.

4.3 Fuzzy controller

The throttle fuzzy controller's inputs are tracking error of MAP (e_p) and its integral. EGR fuzzy controller's inputs are MAF tracking error (e_w) tracking and its integral.

The input membership functions are given in **ผิดพลาด! ไม่พบแหล่งการอ้างอิง** (a)-(b). The output membership functions are given **ผิดพลาด! ไม่พบแหล่งการอ้างอิง** (c). Input linguistic variables of fuzzy controller 1 are "MAP Error" and "Integrated MAP Error". Input linguistic variables of fuzzy controller 2 are "MAF Error" and "Integrated MAF Error". Output linguistic variables of fuzzy controller 1 and 2 are "Delta Throttle" and "Delta EGR", respectively. The fuzzy controller 1 and the fuzzy controller 2 are normalized; all universes of discourse are from -1 to 1. The premise conjunction is "minimum". The defuzzification method is "center of gravity (COG)". Control parameters are set as the following; input gains $a_{11} = 0.0013$, $a_{12} = 0.025$, $a_{21} = 5 \times 10^{-4}$, $a_{22} = 0.025$, and output gains $b_1 = b_2 = 100$.

ผิดพลาด! ไม่พบแหล่งการอ้างอิง: left (a)-(b) contain the rule-bases of the fuzzy systems for the Delta Throttle and Delta EGR. The rule-bases in all cases are symmetrical. The input linguistic numeric values range from "-3" to "3", while the output linguistic number values range from "-4" to "4" as shown in **ผิดพลาด! ไม่พบแหล่งการอ้างอิง**. The **ผิดพลาด! ไม่พบแหล่งการอ้างอิง**: right (a)-(b) show their corresponding control surfaces; where the outputs of fuzzy controller are plotted against

theirs two inputs. The ΔTP_d and ΔEP_d are added to produce appropriate throttle and EGR position set-points.

4.4 Fuzzy supervisor

The fuzzy supervisors, with the interaction parameter (I_f) and engine speed (n) are inputs of the fuzzy supervisory. Comparing to the gain-scheduling methods that are widely implemented in production engine management systems, the use of interaction mechanism in the fuzzy supervisory can reduce the calibration effort drastically.

The interaction term (I_f) is assigned by (2):

$$I_f = |D_w e_{w,f} - D_p e_{p,f}| \quad (2)$$

$e_{p,f}$ and $e_{w,f}$ are MAP tracking error and MAF tracking error which are filtered by the low-pass filters of 1.5 Hertz.

The scaling gains of MAP error and MAF error ($D_p = 1, D_w = 0.3$) are used to rectify the MAF and MAP errors into same expected range. The proposed interaction term indicates the absolute different between the scaled MAF error and the scaled MAP error.

Excessive controller gain at high engine speed brings to the fluctuation of air flow which degrades the control performance, while less controller gain at low speed gives slower control response. In our fuzzy system, the fuzzy supervisory with input n adjusts the standard fuzzy controller gains more appropriately and consistently with engine speed variation.

The interaction parameter is fuzzified to "Interaction". The engine speed parameter is fuzzified to "Engine Speed". Input linguistic variables of fuzzy supervisory 1 and 2 are "Interaction" and "Engine Speed". Output

linguistic variables of the fuzzy supervisory 1 and 2 are "Throttle Gain" and "EGR Gain", respectively. The input membership functions are given in **ชนิดพลาด! ไม่พบแหล่งการอ้างอิง** (d)-(e). The output membership functions are given in **ชนิดพลาด! ไม่พบแหล่งการอ้างอิง** (f). The premise conjunction is "minimum"

are used to adjusted appropriate fuzzy controller input gains.

5. Experimental Results

The designed control system was implemented in the DF-PCCI engine, 2KD-FTV Toyota engine, mounted on a test bed with an engine dynamometer which is programmed to run on the NEDC test. Experiments results show

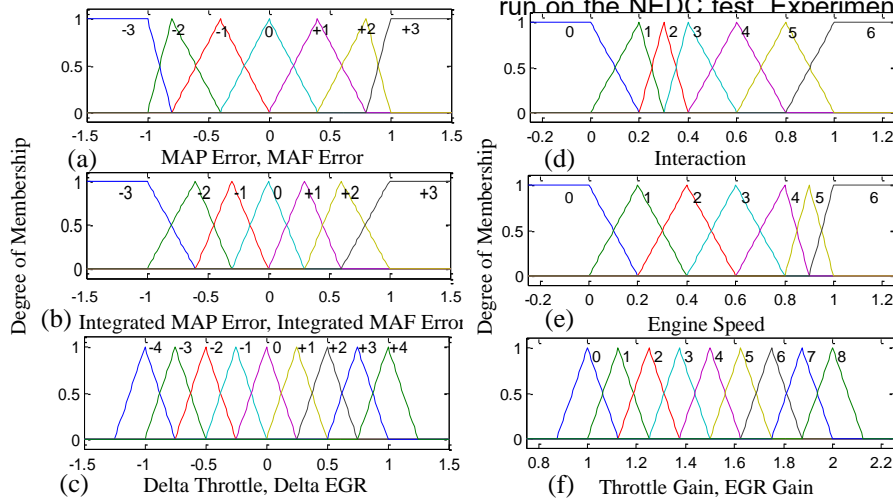

Figure 1: (a) input membership functions of MAP Error and MAF Error, (b) input membership functions of integrated MAP Error and integrated MAF Error, (c) output membership functions of fuzzy controller1 and 2, (d) input membership functions of Interaction, (e) input membership functions of Engine Speed, and (f) output membership functions of fuzzy supervisory1 and 2

The defuzzification method is "center of gravity (COG)". Control parameters are set as the following; $c_{11} = c_{21} = 0.05$, $c_{12} = c_{22} = 2 \times 10^{-4}$, and $d_1 = d_2 = 1$.

ชนิดพลาด! ไม่พบแหล่งการอ้างอิง: left (c) contains the rule-bases of the fuzzy systems for the Throttle Gain and EGR Gain. The input linguistic numeric values range from "0" to "6", while the output linguistic number values range from "0" to "8" as shown in **ชนิดพลาด! ไม่พบแหล่งการอ้างอิง**. The **ชนิดพลาด! ไม่พบแหล่งการอ้างอิง**: right (c) shows its corresponding control surface; where the output of fuzzy controller is plotted against its two inputs. The TP_G and EP_G

the controller performance on the two urban cycles of the NEDC.

Figure 3, shows the worthy MAF and MAP tracking control performance during transient-operation on the NEDC. Figure 4(a), the interaction term enlarges the controller gains, while, Figure 4(b), engine speed reduces the gains. The supervised gains, in Figure 4(c), enhance the controller performance.

In order to compare control performance between the fuzzy supervisory controller and a standard well-tuned fuzzy controller (fixed gains),

the percentage Normalized Sum of Squared tracking Errors (NSSE), NSSE of the finest Fuzzy PI MAF control on full NEDC in [7] is 10.60%, are computed for the each controller. The NSSE of the supervisory fuzzy controller of the MAF and MAP are 5.01 and 2.31 which are improved from a standard well-tuned fuzzy controller as 6.98 and 2.35%, respectively. According to these experimental results, the robustness of controller seems to be reached.

controller gains properly to enhance controller performance and solve the interaction problem. The anti-windup systems operated reasonable. Throttle and EGR position control were worthily controlled by conventional PID control.

Future development will focus on on-line tuning using system response. However, attempt on an actual pick-up truck implementation, with limited computational resources, should be made to apply these control systems.

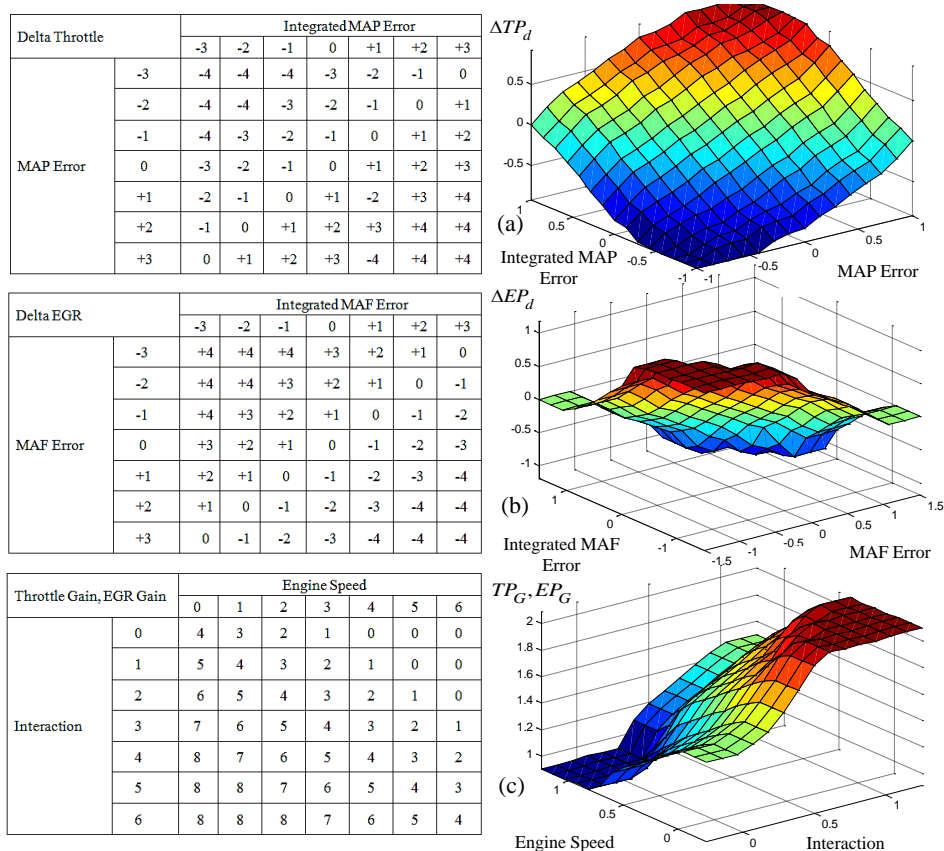

Figure 1: (a) control surface of ΔTP_d , (b) control surface of ΔEP_d , and (c) control surface of TP_G , and EP_G .

6. Summary/ Conclusions

The system identification results presented the primary effects and secondary effects by throttle and EGR which a diagonal decentralized controller is suitable to the system. The complete fuzzy supervisory system was designed to track the MAF and MAP in the engine. Fuzzy supervisors adjusted fuzzy

7. References

- [1] Chatlatanagulchai, W., Yaovaja, K., Rhiensrayoon, S., and Wanatong, K. (2010). Air-Fuel Ratio Regulation with Optimum Throttle Opening in Diesel-Dual-Fuel Engine, *SAE Technical Paper 2010-01-1574*.

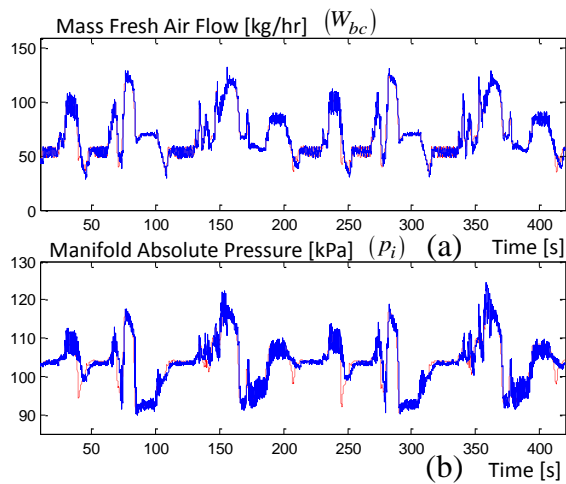

Figure 3: (a) MAF set-points (red dot-line) and feedback MAF (blue solid-line), and (b) MAP set-points (red dot-line) and feedback MAP (blue solid-line) on two urban cycles of the NEDC.

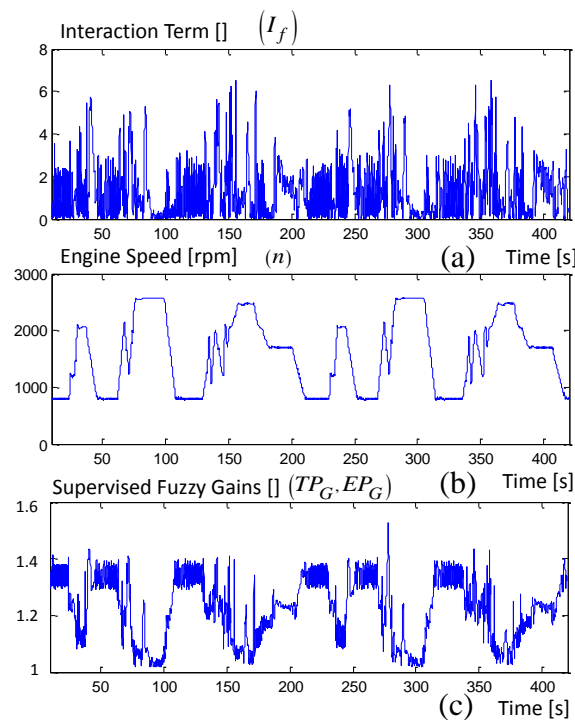

Figure 4: (a) Interaction term, (b) Engine speed, and (c) fuzzy controller input gain on two urban cycles of the NEDC.

[2] Chatlatanagulchai, W., Yaovaja, K., Rhienprayoon, S., and Wanatong, K. (2010). Air/Fuel Ratio Control in Diesel-Dual-Fuel Engine by Varying Throttle, EGR Valve, and Total Fuel, *SAE Technical Paper 2010-01-2200*.

[3] Chatlatanagulchai, W., Pongpanich, N., Rhienprayoon, S., and Wanatong, K. (2010). Quantitative Feedback Control of Air Path in Diesel-Dual-Fuel Engine, *SAE Technical Paper 2010-01-2210*.

[4] Chatlatanagulchai, W., Moonmangmee, I., Rhienprayoon, S., and Wanatong, K. (2011). Sliding Mode Control of Air Path in Diesel-Dual-Fuel Engine, *SAE Technical Paper 2011-01-0917*.

[5] Skogestad, S., and Postlethwaite, I. (2005). Multivariable Feedback Control Analysis and Design, *John Wiley & Sons, Chichester ISBN 0470011688*.

[6] Shamdani, A. H., Shamekhi, A. H. and Ziabasharhagh, M. (2008). Air Intake Modeling with Fuzzy AFR Control of a Turbocharged Diesel Engine, *Int. J. Vehicle System Modelling and Testing, Vol. 3, No. 1/2. 2008*.

[7] Simani, S. and Bonfe, M. (2009). Fuzzy Modeling and Control of the Air System of a Diesel Engine, *Advances in Fuzzy Systems, Hindawi Publishing Corporation, Article ID 450259*

[8] Arnold, J. F., Langlois, N., Chafouk, H. and Tremouliere, G. (2006). Control of the Air System of a Diesel Engine: a Fuzzy Multivariable Approach, *Proc. of the 2006 IEEE International Conference on Control Applications, Munich, Germany, October 4-6, 2006*.

[9] Jung, M. (2003). Mean-Value Modeling and Robust Control of the Airpath of a Turbocharged Diesel Engine, *PhD. Thesis, University of Cambridge, 2003*

[10] Passino, K., and Yurkovich, S. (2008). Fuzzy Control, *Addison-Wesley Longman, Inc.*